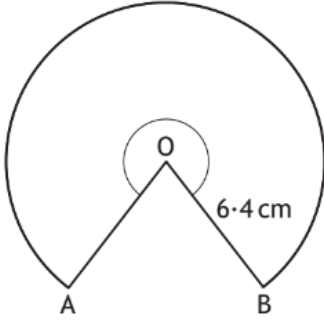

1	Expand and simplify $(2x + 3)(x^2 - 4x + 1)$.
2	Express $x^2 + 8x - 7$ in the form $(x + a)^2 + b$.
3	Simplify $\frac{x^2 - 4x}{x^2 + x - 20}$.
4	<p>A house is valued at £240 000.</p> <p>Its value is predicted to rise by 2.8% per annum.</p> <p>Calculate its predicted value after 2 years.</p>
5	<p>The diagram below shows part of a circle, centre O.</p>  <p>The radius of the circle is 6.4 centimetres.</p> <p>Major arc AB has length 31.5 centimetres.</p> <p>Calculate the size of the reflex angle AOB.</p>

6

Solve, algebraically, the inequality

$$19 + x > 15 + 3(x - 2).$$

7

A carton is in the shape of a large cone with a small cone removed.

The large cone has diameter of 32 cm and height 24 cm.

The small cone has diameter of 18 cm and height 13.5 cm.

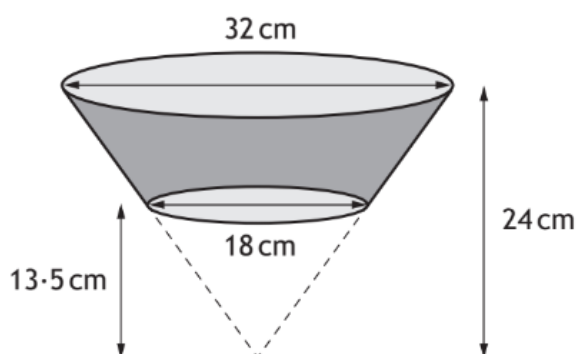

Calculate the volume of the carton.

Give your answer correct to 2 significant figures.

8

Simplify $(n^2)^3 \times n^{-10}$.

Give your answer with a **positive** power.

9

Express

$$\frac{n}{n^2 - 4} \div \frac{3}{n - 2}, \quad n \neq -2, n \neq 2$$

as a single fraction in its simplest form.

10	<p>Jack called his internet provider on six occasions to report connection problems.</p> <p>On each occasion he noted the length of time he had to wait before speaking to an adviser.</p> <p>The times (in minutes) were as follows:</p> <p style="text-align: center;">13 16 10 22 5 12</p> <p>(a) Calculate the mean and standard deviation of these times. 4</p> <p>(b) Sophie also called the same internet provider, on several occasions, to report connection problems.</p> <p>Her mean waiting time was 15 minutes and the standard deviation was 4.3 minutes.</p> <p>Make two valid comments comparing Sophie's waiting times with Jack's waiting times. 2</p>
11	<p>The number of calls received by the police was recorded over 10 days.</p> <p>The results are shown below.</p> <p style="text-align: center;">198 216 218 230 232 247 248 250 265 267</p> <p>a) Find the median and interquartile range</p> <p>b) Draw a box plot</p>
12	<p>Bradley decides to cycle from Kilsyth to the highest point of Tak-Ma-Doon Road.</p> <ul style="list-style-type: none"> • The horizontal distance between these two places is 4.5 kilometres. • Kilsyth is 70 metres above sea level. • The highest point of Tak-Ma-Doon Road is 320 metres above sea level. <p>(a) Calculate the average gradient between Kilsyth and the highest point of Tak-Ma-Doon Road.</p> <p>Give your answer as a fraction in its simplest form.</p> <p>(b) One part of the road has gradient $\frac{2}{25}$.</p> <p>Is this steeper than the average gradient?</p> <p>You must justify your answer.</p>

ANSWERS:

1. $2x^3 - 5x^2 - 10x + 3$

2. $(x + 4)^2 - 23$

3. $\frac{x}{x+5}$

4. £253 628.16

5. 282^0

6. $x < 5$

7. large cone = 6433.98... small cone = 1145.11... volume = 5288.87..

Volume = 5300cm^3 (to 2 sig figs)

8. $\frac{1}{n^4}$

9. $\frac{n}{3(n+2)}$

10. mean = 13 mins s.d = 5.7mins

b) on average Sophies waiting times were longer (

Sophies waiting times were more consistent (

11. a) median = 239.5 IQR = 32

b) ask teacher

12. a) $m = 1/16$ b) Yes, $\frac{1}{16} < \frac{1}{14}$ ($0.07.. > 0.0625$)